

SIGHT FLOW FLANGED 150 lb., 300 lb. & 10 - 25 bar W/ LIGHT / CAMERA CONNECTION P/N

MODEL / CONNECTION	PRESSURE / INDICATOR	SIZE	BODY (WETTED)	FUSEVIEW™ (WETTED)	GASKET (WETTED)	RETAINER / STUD / NUT MATERIAL (NON-WETTED)	TEMP / DUAL	LIGHT / CAMERA TEE CONNECTION		
F	A						A			
A = FLANGED	A = 150 psi STANDARD B = 150 psi FLAPPER C = 150 psi DRIP TUBE D = 150 psi ROTOR E = 300 psi STANDARD F = 300 psi FLAPPER G = 300 psi DRIP TUBE H = 300 psi ROTOR M = 10 bar STANDARD N = 10 bar FLAPPER	P = 10 bar DRIP TUBE Q = 10 bar ROTOR R = 16 bar STANDARD S = 16 bar FLAPPER T = 16 bar DRIP TUBE U = 16 bar ROTOR V = 25 bar STANDARD W = 25 bar FLAPPER Y = 25 bar DRIP TUBE Z = 25 bar ROTOR	C = 1" D = 1.5" E = 2" Y = 2.5" F = 3" G = 4" H = 6" I = 8" J = 10" K = 12"	P = 25mm Q = 40mm R = 50mm S = 65mm T = 80mm U = 100mm V = 150mm W = 200mm Z = 250mm	A = CS B = SS C = ALLOY C D = C276 E = C-22®	A = CS B = SS C = ALLOY C D = C276 E = C-22®	1 = B 2 = V 3 = STFG 4 = SR 5 = GF 6 = TG 7 = BG 8 = PDM 9 = N	1 = CARBON STEEL (STANDARD) 2 = STAINLESS STEEL	A = ↓450°F	(SEE NOTE 3) 1 = 1" NPT 2 = 2" NPT 3 = 1" FLANGE 4 = 1.5" FLANGE 5 = 2" FLANGE 6 = 3" FLANGE 7 = 4" FLANGE 8 = WINDOW MOUNT

BILL OF MATERIALS			
NO.	QTY.	DESCRIPTION	MATERIAL
1	1	SIGHT FLOW BODY	S.S., C.S., C276, C-22®
2	2	RETAINING FLANGE	CARBON STEEL, STAINLESS STEEL
3	16	NUT	2H, B8
4	2	FUSEVIEW™ WINDOW	C.S., S.S., ALLOY C, C276, C-22®
5	2	GASKET	SEE LEGEND FOR OPTIONS
6	4	STUDS	B7, B8
7	1	TEE CONNECTION	TEE CONNECTION

LEGEND
 CS = CARBON STEEL
 SS = 316 STAINLESS STEEL
 C276 = HASTELLOY® C276 OR EQUAL
 C-22® = HASTELLOY® C-22® OR EQUAL

B = BUNA
 V = VITON®
 STFG = SOFT TEFLON®
 SR = SILICONE RUBBER
 GF = GRAFOIL®
 TG = TAN GYLON®
 BG = BLUE GARLOCK® 3000
 EPDM = ETHYLENE PROPYLENE
 N = NEOPRENE

FLANGE SIZE	DIMENSIONS 150 lb.			PRESSURE RATING psig	TEMP. RATING °F	DIMENSIONS 300 lb.			PRESSURE RATING psig	TEMP. RATING °F
	A in.	ØB in.	C in.			A in.	ØB in.	C in.		
1"	5 5/8	1 1/4	4 1/4	150	450	6 7/8	1 1/4	4 1/4	300	450
1 1/2"	6 1/2	1 1/2	5 3/4	150	450	7 1/2	1 1/2	5 3/4	300	450
2"	7 7/8	2	6 3/8	150	450	8 5/8	2	6 3/8	300	450
2 1/2" & 3"	9 3/8	3	7 15/16	150	450	11 3/8	3	8 7/16	300	450
4"	11	4	9 1/2	150	450	13 1/4	4	10 1/2	300	450
6"	14 1/4	6	12 11/16	150	450	21 1/4	6	14 11/16	300	450
8"	16 1/8	8	15 11/16	150	450	22 7/8	8	17 11/16	300	450
10"	24 3/4	9 1/2	21 11/16	150	450					

FLANGE SIZE	DIMENSIONS 10 & 16 bar			PRESSURE RATING bar	TEMP. RATING °C	DIMENSIONS 25 bar			PRESSURE RATING bar	TEMP. RATING °C
	A mm	ØB mm	C mm			A mm	ØB mm	C mm		
25mm	143	28.7	108	10, 16	232	174.8	28.7	108	25	232
40mm	165.1	38.1	146.1	10, 16	232	190.5	38.1	146.1	25	232
50mm	200.1	54.1	162.1	10, 16	232	219.2	54.1	162.1	25	232
65mm	238.3	76.2	200.7	10, 16	232	289.1	76.2	214.4	25	232
80mm	238.3	76.2	200.7	10, 16	232	289.1	76.2	214.4	25	232
100mm	279.4	101.6	241.3	10, 16	232	336.6	101.6	266.7	25	232
150mm	362	152.4	322.1	10, 16	232	539.8	152.4	372.9	25	232
200mm	409.7	190.5	398.3	10, 16	232	581.2	190.5	449.1	25	232
250mm	628.7	241.3	550.7	10, 16	232					

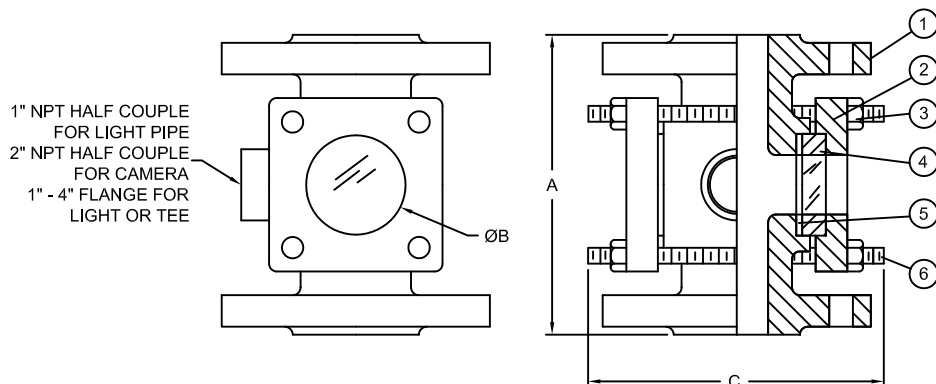

- NOTES:**
- FUSEVIEW™ WINDOWS ARE STANDARD ON ALL SIZES.
 - FLANGED ENDS ARE STANDARD 150 lb. AND 300 lb. ANSI ; 10 bar, 16 bar & 25 bar DIN.
 - TEE CONNECTION MUST BE EQUAL TO OR LESS THAN SIZE OF SIGHT FLOW CONNECTION.
 - CARBON STEEL NON-WETTED IS STANDARD.
 - TEMPERATURE LIMITED BY GASKET SELECTION. SEE 90B2432 FOR RATINGS.
 - HASTELLOY® AND C-22® ARE REGISTERED TRADEMARKS OF HAYNES INTERNATIONAL, INC. TEFLON® AND VITON® ARE REGISTERED TRADEMARKS OF THE DUPONT CORPORATION. GYLON® AND GARLOCK® ARE REGISTERED TRADEMARKS OF THE GARLOCK CORPORATION. GRAFOIL® IS A REGISTERED TRADEMARK OF THE UNION CARBIDE CORPORATION.
 - ALL INFORMATION IS SUBJECT TO CHANGE WITHOUT NOTICE.

<p>NOTICE THIS DRAWING IS THE PROPERTY OF J.M. CANTY AND MUST BE RETURNED WITHOUT REPRODUCTION OR DUPLICATION, AT ANY TIME UPON REQUEST, BUT IN ANY EVENT AS SOON AS IT HAS SERVED THE PURPOSE FOR WHICH IT WAS FURNISHED, WHILE IN THE POSSESSION OF THE RECIPIENT, IT MUST BE PROPERLY SAFEGUARDED AGAINST DISCLOSURE TO ANYONE EXCEPT THOSE EMPLOYEES WHO REQUIRE IT FOR WORK OR JOB. THE RECIPIENT MUST KEEP CONFIDENTIAL AND REQUIRE HIS (HER) EMPLOYEES TO KEEP CONFIDENTIAL THE INFORMATION CONTAINED HERE ON.</p>	DRAWN BY KAZ	DATE 24-Feb-94	J.M. CANTY INC. 6100 DONNER RD. BUFFALO, N.Y. 14094 U.S.A.		J.M. CANTY INTL. LTD. BALLYCOOLIN BUS. PK. BLANCHARDSTOWN DUBLIN 15, IRELAND
	APPROVAL RFM	DATE 24-Feb-94			
	ENGINEERING ANALYSIS CURRENT	DATE			
	MFG. APPROVAL PENDING	DATE			
QUALITY CONTROL I.O.A.	DATE	TITLE SIGHT FLOW FLANGED 150 lb., 300 lb. & 10 - 25 bar W/ LIGHT / CAMERA CONNECTION DIMENSIONS & P/N SELECTION - SALES	SIZE C	REVISION 9	FILE NAME 94B5080
SCALE N.T.S.		SHEET 1 OF 1			