

SCALE 3 / 4

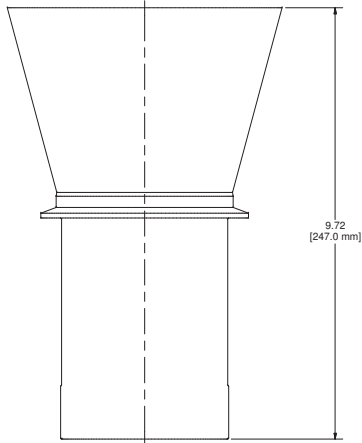

SIDE VIEW  
SCALE 3 / 4

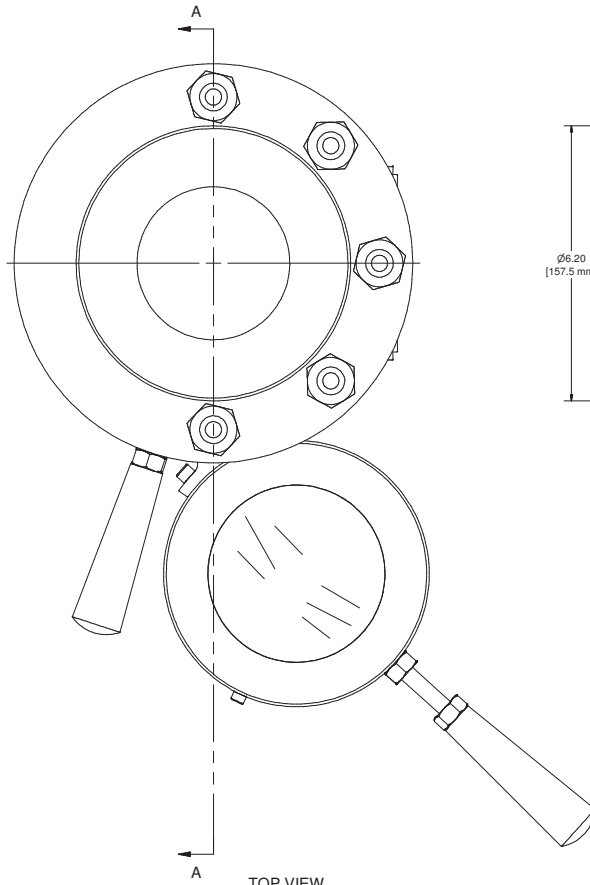

TOP VIEW  
SCALE 3 / 4

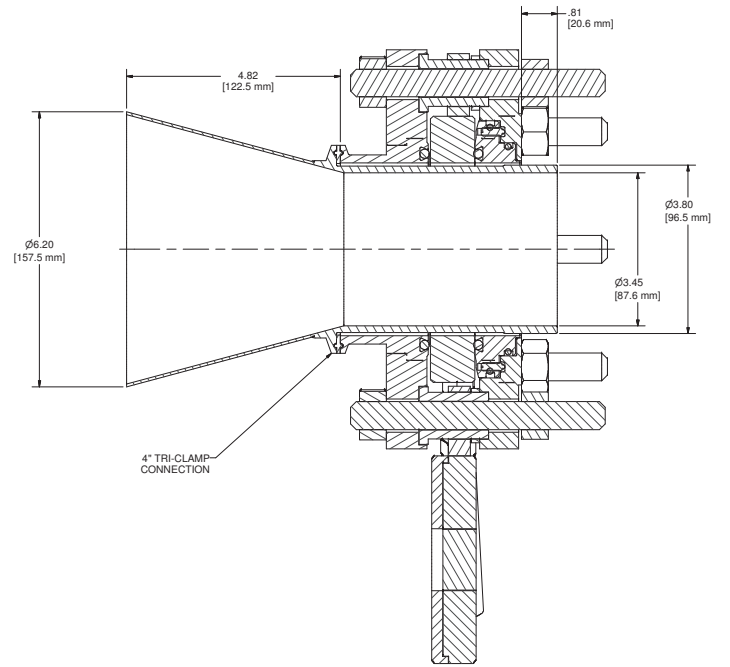

SECTION A-A

- NOTES:**
1. FUNNEL FINISHED PART NO. CD4930-60.
  2. WETTED AND NON-WETTED MATERIALS: 316L S.S.
  3. FUNNEL GASKET SHOWN NOT INCLUDED.

<p><b>NOTICE</b></p> <p>THIS DRAWING IS THE PROPERTY OF J.M. CANTY AND MUST BE RETURNED WITHOUT REPRODUCTION OR DISSEMINATION, AT ANY TIME UPON REQUEST, BUT IN ANY EVENT AS SOON AS IT HAS SERVED THE PURPOSE FOR WHICH IT WAS FURNISHED, WHILE IN THE POSSESSION OF THE RECIPIENT, IT MUST BE PROPERLY SECURED AGAINST DISCLOSURE TO ANYONE EXCEPT THOSE EMPLOYEES WHO ARE EMPLOYED BY THE RECIPIENT AND REQUIRE HIS CONFIDENTIAL AND REQUIRE HIS USER EMPLOYEES TO KEEP CONFIDENTIAL THE INFORMATION CONTAINED HERE ON.</p>		<p><b>IMPORTANT</b></p> <p>FOR THE REQUIRED MANUFACTURING SPECIFICATIONS SEE DOCUMENT #A4955</p> <p>NOTE: FAILURE TO RECEIVE DOCUMENT DOES NOT WAIVE VENDOR RESPONSIBILITY</p>		<p>DRAWN BY</p> <p>RFM</p> <p>APPROVAL</p> <p>RFM</p> <p>ENGINEERING ANALYSIS</p> <p>CURRENT</p> <p>MFG. APPROVAL</p> <p>PENDING</p> <p>QUALITY CONTROL</p> <p>I.O.A.</p>	<p>DATE</p> <p>24-Aug-07</p> <p>DATE</p> <p>24-Aug-07</p> <p>DATE</p> <p>DATE</p> <p>DATE</p> <p>DATE</p> <p>DATE</p> <p>DATE</p>	<p>J.M. CANTY INC.</p> <p>8100 DOWNER RD.</p> <p>BUFFALO, N.Y. 14294</p> <p>U.S.A.</p> <p>WWW.JMCANTY.COM</p>	<p><b>CANTY</b></p> <p>J.M. CANTY INTL. LTD.</p> <p>BALLYCOOLIN BUS. PK.</p> <p>BLANCHARDSTOWN</p> <p>DUBLIN 15, IRELAND</p>
<p>TITLE</p> <p>316L 4" QUICKPORT FUNNEL SALES DETAIL</p>				<p>SIZE</p> <p>D 0</p>	<p>REVISION</p> <p>FILE NAME</p> <p>TA10884-100</p>	<p>SCALE</p> <p>AS NOTED</p>	<p>SHEET</p> <p>1 OF 1</p>