

QUICK CHANGE RUPTURE DISK HOLDER



THE CANTY ADVANTAGE

The Canty Quick Change Rupture Disk allows a single rupture disk user to quickly change, inspect, or clean a rupture disk. This allows increased safety and proper Clean-In-Place standards to be maintained simultaneously. The Quick Change Rupture Disk (QCRD) requires no tools to install and relies on a dual floating o-ring seal. This patented seal ring arrangement is identical to the Canty QuickPorts™ for access, view, and sample ports.

The zero leak design has been proven through a combination of air and liquid submergence testing. This takes the QuickPort™ through external pressure, no pressure, and ultra high internal pressure leak testing where a constant o-ring seal was maintained.

The QCRD integrity is guaranteed through its simple seal ring design, which deflects as the rupture disk is inserted. The original seal ring concept has over 20 years of experience in the hyper baric and diving industry where any operational failure would be fatal.

APPLICATIONS

- Rupture disk replacement in under one minute by a single operator
- Rupture disk inspection
- Facilitates changing disks under relief valves or in difficult areas
- Easily allows disk cleaning (Please consult disk manufacturer for procedure)
- Many, many more!

FEATURES

- No bolting or torquing required
- Zero leak closure
- Full Vacuum
- Code material test reports available
- All types of o-rings available

SPECIFICATIONS

- 1" thru 10"
- 50mm thru 250mm
- ANSI 150 lb., 300 lb., and 600 lb. Mount
- DIN 10 bar, 16 bar, and 40 bar mount
- Stainless steel, Carbon steel, Hastelloy® or equal, or Teflon® construction
- Meets ASME, BS5500, and EC Codes (see interlock options) for quick opening closures
- Code material test reports available
- Designed to interface with ZOOK graphite rupture disks or equivalent and various pretorqued metal disk holders

OPTIONS

- Limit switch to indicate presence or absence of disk
- Pressure interlocks (Not required for code steel)
- Locking options
- Pressurized seal ring interconnected
- Custom sizes or pressures available
- Almost any material of construction is available

QUICK CHANGE RUPTURE DISK SPECIFICATIONS

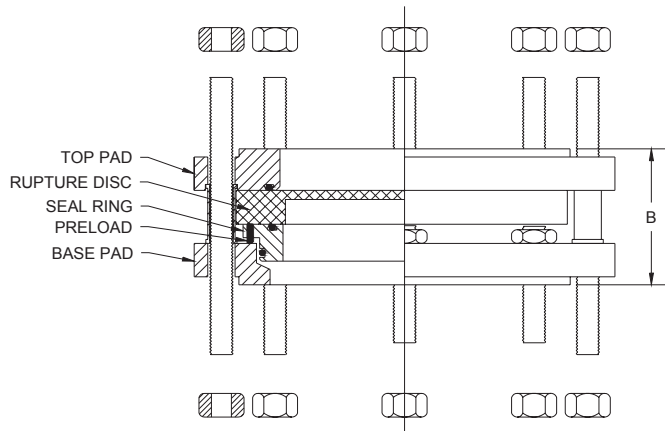
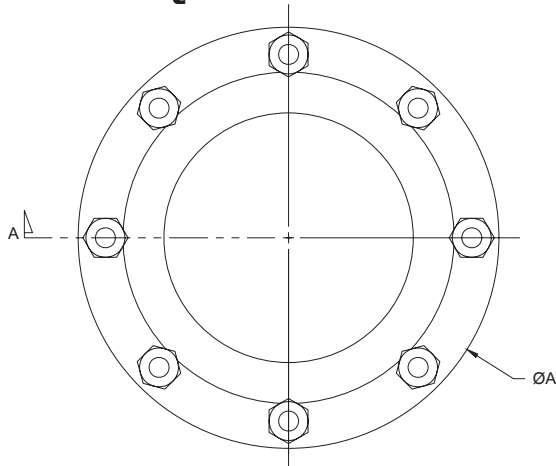

SECTION A-A

As illustrated, the rupture disk holder uses a seal ring which applies an initial force to the disk via the stainless steel preload. Once pressure or vacuum is applied to the rupture disk the floating seal ring adds additional force to seal the disk. When a disk is blown you simply remove it by sliding it out from the holder through the open slot. A replacement can then easily be pushed back into place and the process restarted.

VARIABLE DIMENSION SPECIFICATIONS / 150 lb

SIZE	-A-	-B-	PRESSURE RATING	*MAXIMUM TEMPERATURE
2"	6.00"	2.95"	290 PSI	450°F
3"	7.50"	3.33"	290 PSI	450°F
4"	9.00"	3.33"	250 PSI	450°F
6"	11.00"	3.45"	170 PSI	450°F
8"	13.50"	3.95"	170 PSI	450°F
10"	16.00"	4.45"	150 PSI	450°F

VARIABLE DIMENSION SPECIFICATION / 300 lb

SIZE	-A-	-B-	PRESSURE RATING	*MAXIMUM TEMPERATURE
2"	6.50"	3.33"	400 PSI	450°F
3"	8.25"	4.08"	400 PSI	450°F
4"	10.00"	4.33"	400 PSI	450°F
6"	12.25"	5.20"	350 PSI	450°F
8"	15.00"	6.08"	300 PSI	450°F

VARIABLE DIMENSION SPECIFICATIONS / 600 lb

SIZE	-A-	-B-	PRESSURE RATING	*MAXIMUM TEMPERATURE
2"	6.50"	3.58"	600 PSI	450°F
3"	8.25"	4.33"	600 PSI	450°F

- * TEFLON® SEALRING IS ONLY RATED TO 300F
- * TEMPERATURE IS DEPENDENT ON O-RING MATERIAL
- * "B" DIMENSIONS ARE FOR ZOOK GRAPHITE DISKS OR EQUIVALENT
- * CONSULT FACTORY FOR DIN DIMENSIONS

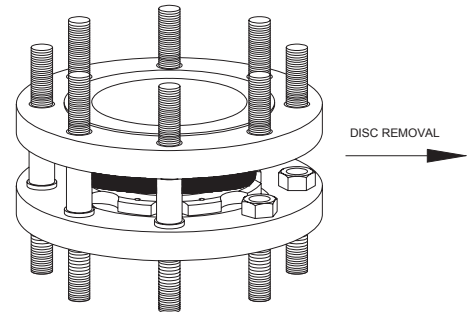

Ordering Information

HOW TO ORDER: Select the appropriate symbols and build a part number as shown:

EXAMPLE:

SIZE:

- | | |
|-------------|------------|
| <u>ANSI</u> | <u>DIN</u> |
| 1 = 2" | A = 50mm |
| 2 = 3" | B = 80mm |
| 3 = 4" | C = 100mm |
| 4 = 6" | D = 150mm |
| 5 = 8" | E = 200mm |
| 6 = 10" | K = 250mm |

PRESSURE:

- | | |
|-------------|------------|
| <u>ANSI</u> | <u>DIN</u> |
| A = 150 psi | 1 = 10 BAR |
| B = 300 psi | 2 = 16 BAR |
| D = 600 psi | 3 = 40 BAR |

WETTED MATERIAL (process side):

- BB = 316L Stainless Steel
- DD = Hastelloy® C276 or equal
- EE = Hastelloy® C-22® or equal
- II = Teflon®

GRAPHITE DISK:

- Zook or Equivalent
- Consult factory for metal disks

SEAL RING OPTIONS:

- A = Standard
- B = Self Pressurized
- C = Spray Ring

O-RING (wetted):

- 1 = Buna [225°F / 107°C]
- 2 = Viton® [400°F / 204°C]
- 4 = Silicone [450°F / 232°C]
- 8 = EPDM [300°F / 149°C]
- 9 = Neoprene [250°F / 121°C]
- A = Kalrez® [450°F / 232°C]
- B = Chemraz® [450°F / 232°C]

WETTED MATERIAL (vent side):

- B = 316 L Stainless Steel
- D = Hastelloy® C276 or equal
- E = Hastelloy® C-22® or equal

CANTY

JM Canty Inc | Buffalo, NY USA
JM Canty Intl Ltd | Dublin, Ireland

Ph: (716) 625 4227
Ph: + 353 (01) 882 9621

Fax: (716) 625 4228
Fax: +353 (01) 882 9622

www.jmcanty.com

Document P/N: TA6525-1 Rev 1

Viton®, Teflon®, & Kalrez® are registered trademarks of the Dupont Corp., Dover Pac® is a registered trademark of the ILC Dover Corp. Tri-clamp® is a registered trademark of Alfa Laval Inc., Chemraz® is a registered trademark of the Greene Tweed Inc. Hastelloy® and C-22® are registered trademarks of Haynes International, Inc.