

CANTY

PROCESS TECHNOLOGY

F700 SERIES FLANGED SIGHT FLOWS



THE CANTY ADVANTAGE

J.M. Canty F700 series flanged sight flows have been engineered to meet all your process and piping needs. Our sight flows have been designed to meet strict ASME code requirements. Canty hydro-tests all units to 150% of the maximum rated pressure and can provide certification of material and testing if required, typical of ASME code requirements for process vessels.

UNMATCHED SAFETY, RELIABILITY

All Canty sight flows feature the Fuseview™ window. Our unique fused glass windows far exceed all conventional tempered glass windows in safety and performance. By fusing glass to metal, a high pressure, high safety, hermetic seal is formed. This fused glass technology ensures safety with every F700 series sight flow. What's more, our windows can easily be removed for cleaning. Canty windows do not have to be discarded, as do traditional tempered glass windows. Canty fused glass windows can be re-used again and again.

FEATURES

- All sight flows feature Canty Fuseviews™
- Castings, designed to ASME code
- Connections per ANSI 16.5 and BS EN 1092-1
- Stainless steel, carbon steel, and Hastelloy® bodies and Fuseviews™
- Teflon® lined sight flows are available
- 150 LB through 2500 LB, PN10 through PN100
- Special pressures though 10,000 PSI are available

UNIQUE OPTIONS

- Dual fused glass option – for high temperature applications
- Lighting – 90 degree lighting to illuminate your Process without eliminating a sight glass
- Optional camera or interface sensor – to remotely view and control your process

FEATURES OF THE FUSEVIEW™

- *Models feature FM approved windows !*
- Extremely high strength due to radial compression on the hermetically sealed glass
- Eliminates chance of catastrophic failure due to bolt-up
- Very high impact strength due to prestressing
- Manufactured in nickel plated carbon steel, Stainless steel, or high corrosion resistant Hastelloy®
- Certification on material and pressure rating is available, typical of ASME code requirements

CANTY FUSEVIEWS™ VS. OTHERS

- No bolt loading on the glass. All loading is carried by the fusing ring
- The Fuseview™ sight glass allows the use of standard process gasketing. No special gaskets are required
- No loss of glass temper over time !
- Canty Fuseviews™ may be removed for cleaning and inspection. This is not allowed with ordinary glass, due to residual stresses incurred at bolt-up

INDICATORS

Canty F700 series flanged sight flows are available with various indicator options, including:

- No indicator
- Rotor
- Flapper
- Drip Tube

CANTY

JM Canty Inc | Buffalo, NY USA
JM Canty Intl Ltd | Dublin, Ireland

Ph: (716) 625 4227
Ph: + 353 (01) 882 9621

Fax: (716) 625 4228
Fax: +353 (01) 882 9622

www.jmcanty.com

F700 SIGHT FLOW INDICATOR SPECIFICATIONS

150 LB / PN10 / PN16

SIZE	"A"	"ØB"	"C"
1/2" / 15 mm	7.50" [190.5mm]	1.13" [28.7mm]	4.00" [101.6mm]
3/4" / 20 mm	7.88" [200.2mm]	1.13" [28.7mm]	4.00" [101.6mm]
1" / 25 mm	5.63" [143mm]	1.13" [28.7mm]	4.25" [108mm]
1.5" / 40 mm	6.50" [165.1mm]	1.50" [38.1mm]	5.75" [146.1mm]
2" / 50 mm	7.88" [200.1mm]	2.13" [54.1mm]	6.38" [162.1mm]
2.5" / 65 mm	9.38" [238.3mm]	3.00" [76.2mm]	7.90" [200.7mm]
3" / 80 mm	9.38" [238.3mm]	3.00" [76.2mm]	7.90" [200.7mm]
4" / 100 mm	11.00" [279.4mm]	4.00" [101.6mm]	9.50" [241.3mm]
6" / 150 mm	14.25" [362mm]	6.00" [152.4mm]	12.68" [322.1mm]
8" / 200 mm	16.13" [409.7mm]	7.50" [190.5mm]	15.68" [398.3mm]
10" / 250 mm	24.75" [628.7mm]	9.50" [241.3mm]	21.68" [550.7mm]
12"	25.75" [654mm]	9.50" [241.3mm]	25.00" [635mm]
14"	26.75" [679.5mm]	9.50" [241.3mm]	26.50" [673.1mm]
16"	26.75" [679.5mm]	9.50" [241.3mm]	28.50" [723.9mm]

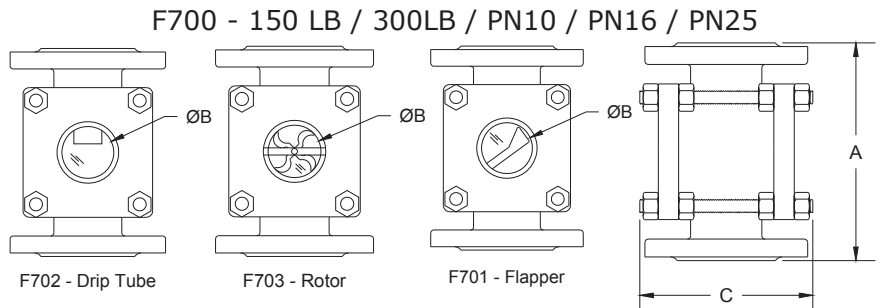

F700 - 150 LB / 300LB / PN10 / PN16 / PN25

F700TFE - TEFLON LINED - 150 LB

SIZE	"A"	"ØB"	"C"
1"	7.0" [177.8mm]	1.13" [28.7mm]	5.00" [127mm]
1.5"	8.0" [203.2mm]	1.50" [38.1mm]	5.88" [149.4mm]
2"	9.0" [228.6mm]	2.00" [50.8mm]	7.50" [190.5mm]
3"	11.0" [279.4mm]	3.00" [76.2mm]	8.88" [225.6mm]
4"	13.0" [330.2mm]	4.00" [101.6mm]	9.88" [251mm]
6"	17.0" [431.8mm]	6.00" [152.4mm]	12.25" [311.2mm]
8"	20.0" [508mm]	8.00" [203.2mm]	15.50" [393.7mm]

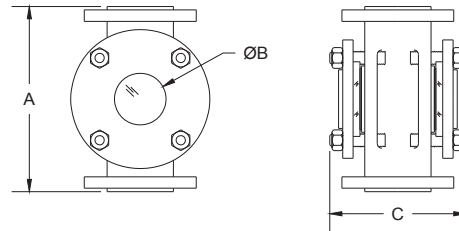

F700TFE - Teflon® Lined

300 LB / PN25

SIZE	"A"	"ØB"	"C"
1/2" / 15 mm	7.88" [200.2mm]	1.13" [28.7mm]	4.00" [101.6mm]
3/4" / 20 mm	8.25" [209.6mm]	1.13" [28.7mm]	4.00" [101.6mm]
1" / 25 mm	6.88" [174.8mm]	1.13" [28.7mm]	4.25" [108mm]
1.5" / 40 mm	7.50" [190.5mm]	1.50" [38.1mm]	5.75" [146.1mm]
2" / 50 mm	8.63" [219.2mm]	2.13" [54.1mm]	6.38" [162.1mm]
2.5" / 65 mm	11.38" [289.1mm]	3.00" [76.2mm]	8.44" [214.4mm]
3" / 80 mm	11.38" [289.1mm]	3.00" [76.2mm]	8.44" [214.4mm]
4" / 100 mm	13.25" [336.6mm]	4.00" [101.6mm]	10.50" [266.7mm]
6" / 150 mm	21.25" [539.8mm]	6.00" [152.4mm]	14.68" [372.9mm]
8" / 200 mm	22.88" [581.2mm]	7.50" [190.5mm]	17.68" [449.1mm]

Ordering Information

HOW TO ORDER: Select the appropriate symbols and build a part number as shown:

EXAMPLE:

F ——— **O**

MODEL: _____

A = Flanged

E = Flanged Teflon® lined

PRESSURE / INDICATOR: _____

A = 150 LB Plain

B = 150 LB Flapper

C = 150 LB Drip Tube

D = 150 LB Rotor

E = 300 LB Plain

F = 300 LB Flapper

G = 300 LB Drip Tube

H = 300 LB Rotor

3 = 150 LB Teflon® Lined

M = PN10 Plain

N = PN10 Flapper

P = PN10 Drip Tube

Q = PN10 Rotor

R = PN16 Plain

S = PN16 Flapper

T = PN16 Drip Tube

U = PN16 Rotor

V = PN25 Plain

W = PN25 Flapper

Y = PN25 Drip Tube

Z = PN25 Rotor

TEMPERATURE: _____

*A = 450°F [232°C] max (Flanged)

B = 400°F [204°C] max (Teflon® Lined)

* See gasket ratings for actual temperature rating

RETAINER / BOLTING MATERIAL (non-wetted): _____

1 = Carbon Steel Painted (Standard)

2 = 304 Stainless Steel

GASKET MATERIAL (wetted): _____

1 = Buna [225°F / 107°C]

2 = Viton® [400°F / 204°C]

3 = Soft Teflon® [450°F / 232°C]

4 = Silicone Rubber [450°F / 232°C]

5 = Grafoil® [450°F / 232°C]

6 = Tan Gylon® 3500 [450°F / 232°C]

7 = Blue Garlock® 3000 [450°F / 232°C]

8 = Ethylene Propylene - EPDM [300°F / 149°C]

9 = Neoprene [250°F / 121°C]

B = Teflon® Envelope (Teflon® lined only) [400°F / 204°C]

BODY / FUSEVIEW™ MATERIAL (wetted): _____

AA = Carbon Steel (body - ASTM A216 WCB)

BB = 316 Stainless Steel** (body - ASTM A351 CF8M)

CC = Alloy C

DD = Hastelloy® C276 or equal

EE = Hastelloy® C-22® or equal

AG = Carbon Steel Teflon® Lined with Glass Wetted Fuseviews™

SIZE: _____

A = .5"

G = 4"

M = 15 mm

T = 80 mm

B = .75"

H = 6"

N = 20 mm

U = 100 mm

C = 1"

I = 8"

P = 25 mm

V = 150 mm

D = 1.5"

J = 10"

Q = 40 mm

W = 200 mm

E = 2"

K = 12"

R = 50 mm

Z = 250 mm

Y = 2.5"

L = 14"

S = 65 mm

F = 3"



**Canty reserves the right to upgrade the Fuseviews™ to Hastelloy® C-family of alloys or equal at their own cost.

CANTY

JM Canty Inc

Buffalo, NY USA

Ph: (716) 625 4227

Fax: (716) 625 4228

JM Canty Intl Ltd

Dublin, Ireland

Ph: + 353 (01) 882 9621

Fax: +353 (01) 882 9622

www.jmcanty.com