

CANTY

PROCESS TECHNOLOGY

S100 SERIES THREADED / WELDED SIGHT FLOWS



THE CANTY ADVANTAGE

J.M. Canty S100 series threaded/welded sight flows have been engineered to meet all your process and piping needs. Our Sight flows have been designed to meet strict ASME code requirements. Canty hydro-tests all units to 150% of the maximum rated pressure and can provide certification of material and testing if required, typical of ASME code requirements for process vessels.

UNMATCHED SAFETY, RELIABILITY

All Canty Sight flows feature the Fuseview™ window. Our unique fused glass windows far exceed all conventional tempered glass windows in safety and performance. By fusing glass to metal, a high pressure, high safety, hermetic seal is formed. This fused glass technology ensures safety with every S100 series Sight flow. What's more, our windows can easily be removed for cleaning. Canty windows do not have to be discarded, as do traditional tempered glass windows. Canty fused glass windows can be re-used again and again.

UNIQUE OPTIONS

- Dual fused glass option - for high temperature applications
- Connections-Sanitary and Swagelok® connections are available

INDICATORS

Canty S100 series flanged Sight flows are available with various indicator options, including:

- No indicator
- Rotor
- Flapper
- Drip Tube



FEATURES

- All Sight Flows feature Canty Fuseviews™.
- Models feature FM approved Fuseviews™!
- Bodies designed to ASME code
- Stainless steel, carbon steel, and Hastelloy® or equal bodies
- NPT thread, straight thread, and pipe or tube weld Connections are available
- 150# though 3000# models
- Special pressures though 10,000 PSI are available

CANTY FUSEVIEW™ VS OTHERS

- No bolt loading on the glass. All loading is carried by the fusing ring
- The Fuseview™ Sight glass allows the use of standard process gasketing. No special gaskets are required
- No loss of glass temper over time !
- Canty Fuseviews™ may be removed for cleaning and inspection. This is not allowed with ordinary glass, due to residual stresses incurred at bolt-up

FEATURES OF THE FUSEVIEW™

- Extremely high strength due to radial compression on the hermetically sealed glass
- Eliminates chance of catastrophic failure due to bolt-up
- Very high impact strength due to prestressing

CANTY FUSEVIEW™ VS METALGLASS

- Largest view in the Industry. When you order a 4" window you get a 4" view!
- Fuseviews™ are made with excellent corrosion resistant high nickel alloys C, C276 and Hastelloy® C-22® or equal, not duplex stainless steels.
- Boro Plus™ fused glass is superior to other glass with ideal optical and fusing properties. It readily fuses to steel making a one piece hermitically sealed window capable of high pressures and temperatures.
- Ideal properties of metal and glass provides true fusion of glass to metal. This provides a stronger safer fuse that will not crack during installation or operation like borosilicate and duplex stainless steels.
- Superior impact, thermal shock, and pressure resistance from the use of optimum materials and the proper fusing process during manufacturing.

CANTY JM Canty Inc
JM Canty Intl Ltd

Buffalo, NY USA
Dublin, Ireland

Ph: (716) 625 4227
Ph: + 353 (01) 882 9621

Fax: (716) 625 4228
Fax: +353 (01) 882 9622

www.jmcanty.com

S100 SIGHT FLOW INDICATOR SPECIFICATIONS

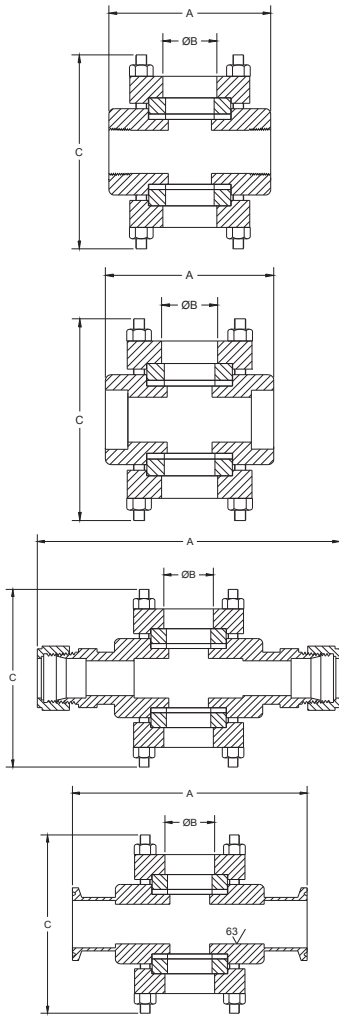

THREADED CONNECTIONS



Note: For factory mutual approval
Consult the factory

WELDED CONNECTIONS

SWAGELOK® CONNECTIONS

SANITARY CONNECTIONS

THREADED / WELDED DIMENSIONS

| PIPE SIZE | A | B | C | |
|-----------|---------------|--------------|---------------------------------------|--|
| | | | 150 PSI [10 bar] 1000 PSI [69 bar] | 2000 PSI [138 bar] 3000 PSI [207 bar] |
| 1/8" | 3.75" [95mm] | 1.13" [29mm] | 4.00" [102mm] | 5.75" [146mm] |
| 1/4" | 3.75" [95mm] | 1.13" [29mm] | 4.00" [102mm] | 5.75" [146mm] |
| 3/8" | 3.75" [95mm] | 1.13" [29mm] | 4.00" [102mm] | 5.75" [146mm] |
| 1/2" | 3.75" [95mm] | 1.13" [29mm] | 4.00" [102mm] | 5.75" [146mm] |
| 3/4" | 3.75" [95mm] | 1.13" [29mm] | 4.00" [102mm] | 5.75" [146mm] |
| 1" | 3.75" [95mm] | 1.13" [29mm] | 4.00" [102mm] | 5.75" [146mm] |
| 1 1/4" | 6.00" [152mm] | 1.50" [38mm] | 5.88" [149mm] | 7.13" [181mm] |
| 1 1/2" | 6.00" [152mm] | 1.50" [38mm] | 5.88" [149mm] | 7.13" [181mm] |
| 2" | 6.00" [152mm] | 2.00" [51mm] | 6.38" [162mm] | 7.63" [194mm] |

SWAGELOK® DIMENSIONS

| PIPE SIZE | A | B | C | |
|-----------|---------------|--------------|---------------------------------------|--|
| | | | 150 PSI [10 bar] 1000 PSI [69 bar] | 2000 PSI [138 bar] 3000 PSI [207 bar] |
| 1/4" | 5.73" [146mm] | 1.13" [29mm] | 4.00" [102mm] | 5.75" [146mm] |
| 3/8" | 5.89" [150mm] | 1.13" [29mm] | 4.00" [102mm] | 5.75" [146mm] |
| 1/2" | 6.61" [168mm] | 1.13" [29mm] | 4.00" [102mm] | 5.75" [146mm] |
| 3/4" | 6.73" [171mm] | 1.13" [29mm] | 4.00" [102mm] | 5.75" [146mm] |
| 1" | 7.65" [194mm] | 1.13" [29mm] | 4.00" [102mm] | 5.75" [146mm] |

SANITARY DIMENSIONS

| TUBE SIZE | A | B | C | PRESSURE IS LIMITED TO RATING OF CLAMP USED. FUSED GLASS IS RATED TO 150 PSI [10 bar] |
|-----------|---------------|--------------|---------------|---|
| 1/2" | 6.00" [152mm] | 1.13" [29mm] | 4.00" [102mm] | |
| 3/4" | 6.00" [152mm] | 1.13" [29mm] | 4.00" [102mm] | |
| 1" | 7.00" [178mm] | 1.13" [29mm] | 4.00" [102mm] | |
| 1 1/2" | 9.25" [235mm] | 1.50" [38mm] | 5.88" [149mm] | |
| 2" | 9.50" [241mm] | 2.00" [51mm] | 6.38" [162mm] | |

Ordering Information

HOW TO ORDER: Select the appropriate symbols and build a part number as shown:

EXAMPLE:

F ——— **A 0**

MODEL:

- B = Pipe Weld
- N = Tube Weld
- C = NPT Thread
- D = Straight Thread
- J = Swagelok®
- L = Tri-clamp®

PRESSURE / INDICATOR:

- M = 150 LB Plain U = 2000 LB Plain
- N = 150 LB Flapper V = 2000 LB Flapper
- O = 150 LB Drip Tube W = 2000 LB Drip Tube
- P = 150 LB Rotor X = 2000 LB Rotor
- Q = 1000 LB Plain Y = 3000 LB Plain
- R = 1000 LB Flapper Z = 3000 LB Flapper
- S = 1000 LB Drip Tube 1 = 3000 LB Drip Tube
- T = 1000 LB Rotor 2 = 3000 LB Rotor

SIZE:

- Z = 1/8" Q = 1"
- M = 1/4" R = 1 1/4"
- N = 3/8" S = 1 1/2"
- O = 1/2" T = 2"
- P = 3/4"

RETAINER / BOLTING MATERIAL:

- (non-wetted):
- 1 = Carbon Steel
- 2 = 304 Stainless Steel

GASKET MATERIAL (wetted):

- *1 = Buna [225°F / 107°C]
- *2 = Viton® [400°F / 204°C]
- 3 = Soft Teflon® [450°F / 232°C]
- *A = Teflon® Encapsulated Silicone [450°F / 232°C]
- *4 = Silicone Rubber [450°F / 232°C]
- 5 = Grafoil® [450°F / 232°C]
- 6 = Tan Gylon® 3500 [450°F / 232°C]
- 7 = Blue Garlock® 3000 [450°F / 232°C]
- *8 = Ethylene Propylene - EPDM [300°F / 149°C]
- *9 = Neoprene [250°F / 121°C]

BODY / FUSEVIEW MATERIAL (wetted):

- AA = Carbon Steel
- BB = 316L Stainless Steel**
- DD = Hastelloy® C276 or equal
- EE = Hastelloy® C-22® or equal

*On 2000 and 3000 models, units are o-ring sealed. Only these materials are available.

**Canty reserves the right to upgrade to Hastelloy® C-family of alloys or equal at their own cost.

CANTY

JM Canty Inc
JM Canty Intl Ltd

Buffalo, NY USA
Dublin, Ireland

Ph: (716) 625 4227
Ph: + 353 (01) 882 9621

Fax: (716) 625 4228
Fax: +353 (01) 882 9622

www.jmcanty.com

Document P/N: TA7462-1 Rev 2

Tri-Clamp® is a registered trademark of Alfa Laval Inc.
Viton® and Teflon® are registered trademarks of the Dupont Corp.
Gylon® and Garlock® are registered trademarks of the Garlock Corp.
Grafoil® is a registered trademark of the Union Carbide Corp.
Swagelok® is a registered trademark of the Swagelok Corp.