

ULTRASONIC LIQUID SAMPLING SYSTEM

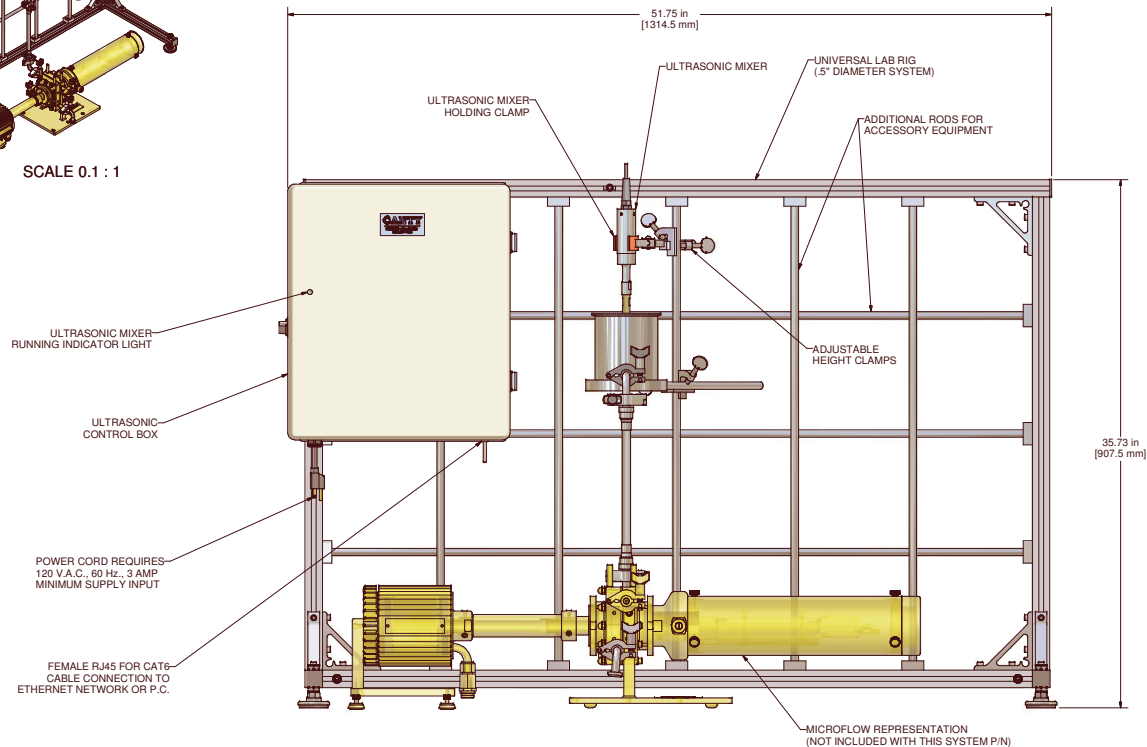

FRONT
SCALE 0.25 : 1

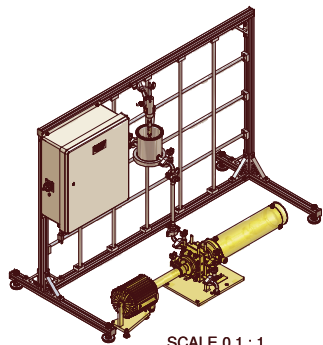
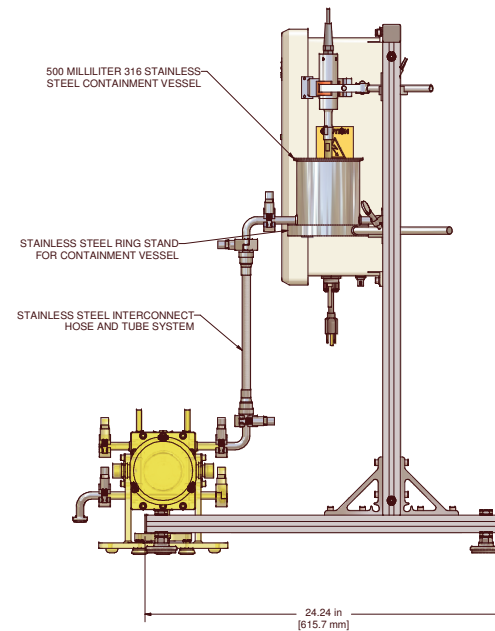

NOTES:

1. THE SYSTEM PART NUMBER VD10691-200 INCLUDES ALL EQUIPMENT SHOWN WITH THE EXCEPTION OF THE MICROFLOW. IT IS JUST A REPRESENTATION TO SHOW ITS LOCATION RELATIVE TO THE UNIVERSAL LAB RIG.
2. THE ULTRASONIC CONTROL BOX REQUIRES CANTYVISION CLIENT SOFTWARE ON A COMPUTER TO INITIATE AND CONTROL FUNCTIONALITY.
3. THE SAMPLE IS MIXED IN THE CONTAINMENT VESSEL AND FLOWS THROUGH THE STAINLESS HOSE AND TUBING TO THE MICROFLOW. THE SAMPLE TRAVELS THROUGH THE ANALYSIS CELL OF THE MICROFLOW AND EXITS OUT THE LOWER 90 DEGREE ELBOW TO BE RECOVERED.
4. THE SYSTEM CAN ALSO BE CONFIGURED TO MINIMIZE THE REQUIRED AMOUNT OF SAMPLE BY DIRECTLY COUPLING THE CONTAINMENT VESSEL DIRECTLY TO THE MICROFLOW ELIMINATING THE STAINLESS HOSE AND TUBING. THIS IS ALSO A BENEFIT TO REDUCE THE SAMPLE SPEED AT HIGHER MAGNIFICATIONS.
5. FOR PARTICLES THAT ARE WELL SUSPENDED OR HAVE HIGH BUOYANCY THE STAINLESS HOSE AND TUBING CAN BE CONFIGURED TO ENTER THE MICROFLOW IN THE LOWER SANITARY CONNECTION AND EXIT OUT THE UPPER CONNECTION.

<p>NOTICE THIS DRAWING IS THE PROPERTY OF J.M. CANTY AND MUST BE RETURNED WITHOUT REPRODUCTION OR DUPLICATION, AT ANY TIME UPON REQUEST, BUT IN ANY EVENT AS SOON AS IT HAS SERVED THE PURPOSE FOR WHICH IT WAS FURNISHED, WHILE IN THE POSSESSION OF THE RECIPIENT, IT MUST BE PROPERLY safeguarded AGAINST DISCLOSURE TO ANYONE EXCEPT THOSE EMPLOYEES WHO ARE EMPLOYED BY THE RECIPIENT AND REQUIRE HIS/HER EMPLOYEES TO KEEP CONFIDENTIAL THE INFORMATION CONTAINED HEREON.</p>		<p>IMPORTANT FOR THE REQUIRED MANUFACTURING SPECIFICATIONS SEE DOCUMENT #A4955</p>		<p>DRAWN BY: MFR DATE: 12-Apr-07</p>	<p>J.M. CANTY INC. 8100 DORNER RD. BUFFALO, N.Y. 14294 U.S.A.</p>	<p>CANTY WWW.JMCANTY.COM</p>	<p>J.M. CANTY INTL. LTD. BALLYCOOLIN BUS. PK. BLANCHARDSTOWN DUBLIN 15, IRELAND</p>
<p>NOTE: FAILURE TO RECEIVE DOCUMENT DOES NOT WAIVE VENDOR RESPONSIBILITY</p>		<p>APPROVAL: MFR DATE: 02-May-07</p>	<p>ENGINEERING ANALYSIS: CURRENT DATE:</p>	<p>TITLE: SALES DOCUMENT, ULTRASONIC LIQUID SAMPLING SYSTEM INFORMATION SHEET</p>			
		<p>MFG. APPROVAL: PENDING DATE:</p>	<p>QUALITY CONTROL: I.O.A. DATE:</p>	<p>SIZE REVISION: D 0</p>	<p>FILE NAME: TD10691-210</p>	<p>SHEET 1 OF 1</p>	